

Networking at LVNL

Air Traffic Control The Netherlands



Agenda

- Intro
 - Speaker
 - Air Traffic Control the Netherlands
 - Networks in ATC
- Technical environment
 - Networks @LVNL
 - Applications
- How do we do it
 - Requirements / choices / tradeoffs
 - Evolution vs revolution
- Future
 - Next steps

Intro speaker

Speaker

Rudi van Drunen

- Network Engineer
- 1.5 yrs of LVNL history
- Hardware – Systems – Software – Networking
- Loves the lower parts of the stack
- NLUUG Chairman of the Board, Ham radio, photography



Air Traffic Control the Netherlands

Organization

- “Zelfstandig Bestuursorgaan” (sinds 1993)
- Income from levies

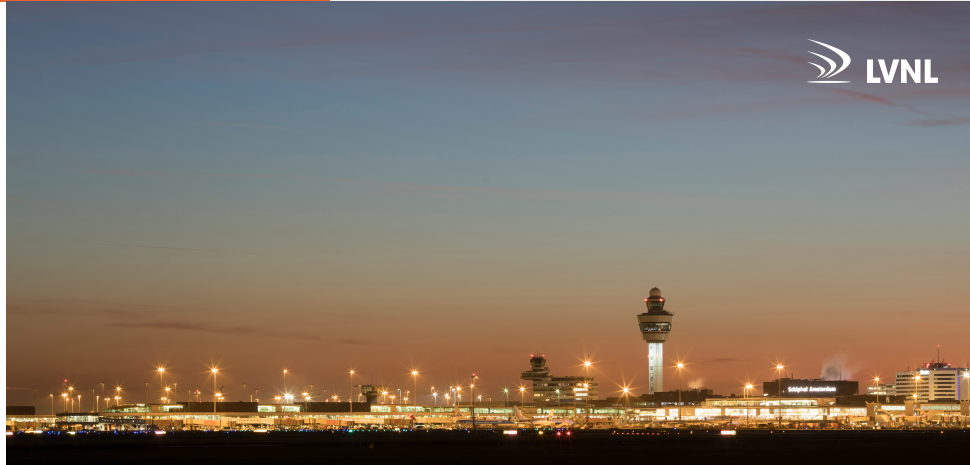

1000

colleagues

350

Ops colleagues

250

Air Traffic Controllers

614.396

*transit (airspace)

499.446

Schiphol

71.000.000

Passengers @ Schiphol

488.904

416.455

71.000.000

2019
2022

Locaties LVNL

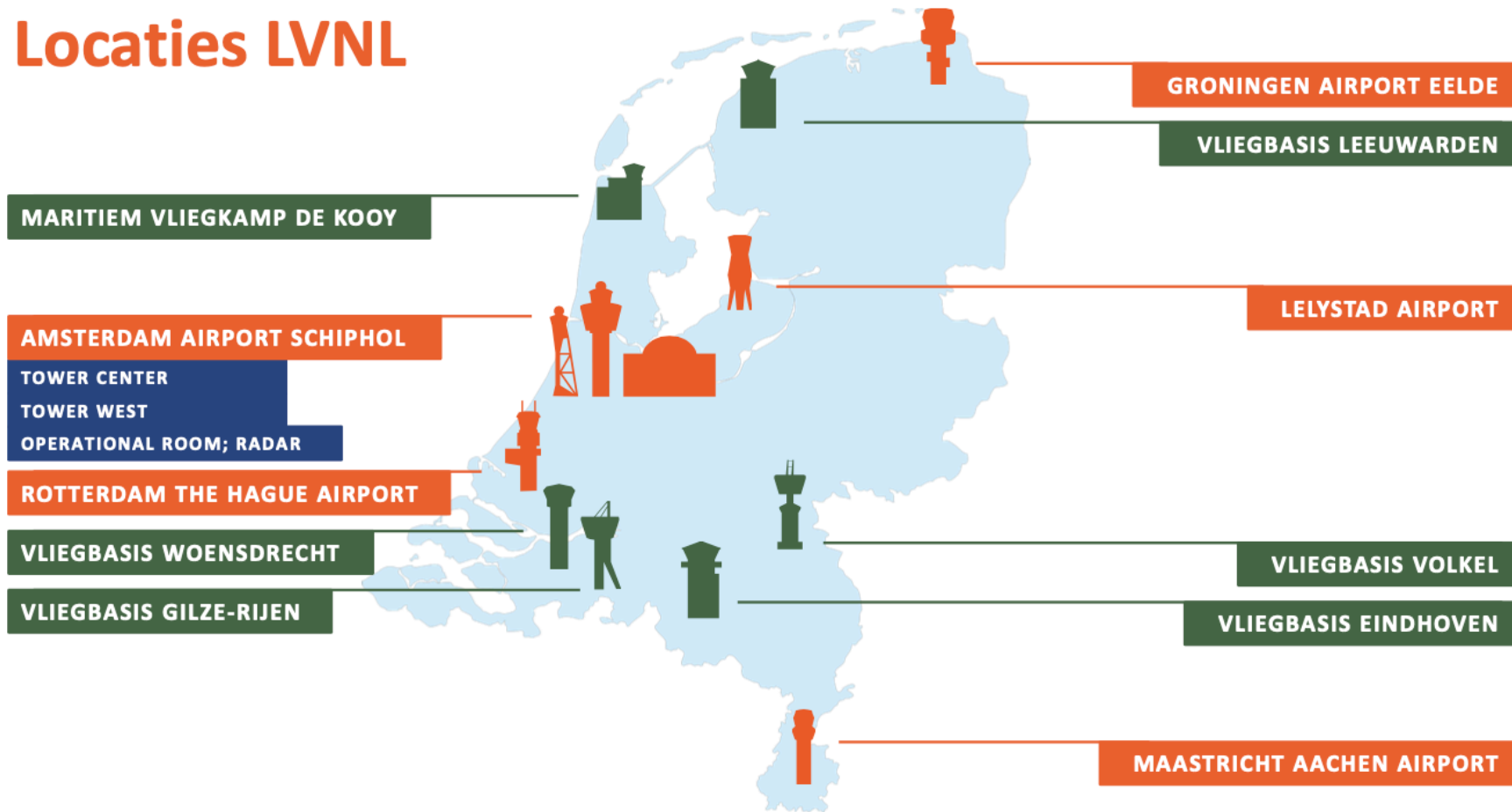



Location Schiphol

- Area Control
- Approach
- Tower



Schiphol Tower Center

Schiphol Oost Headquarters

Units LVNL

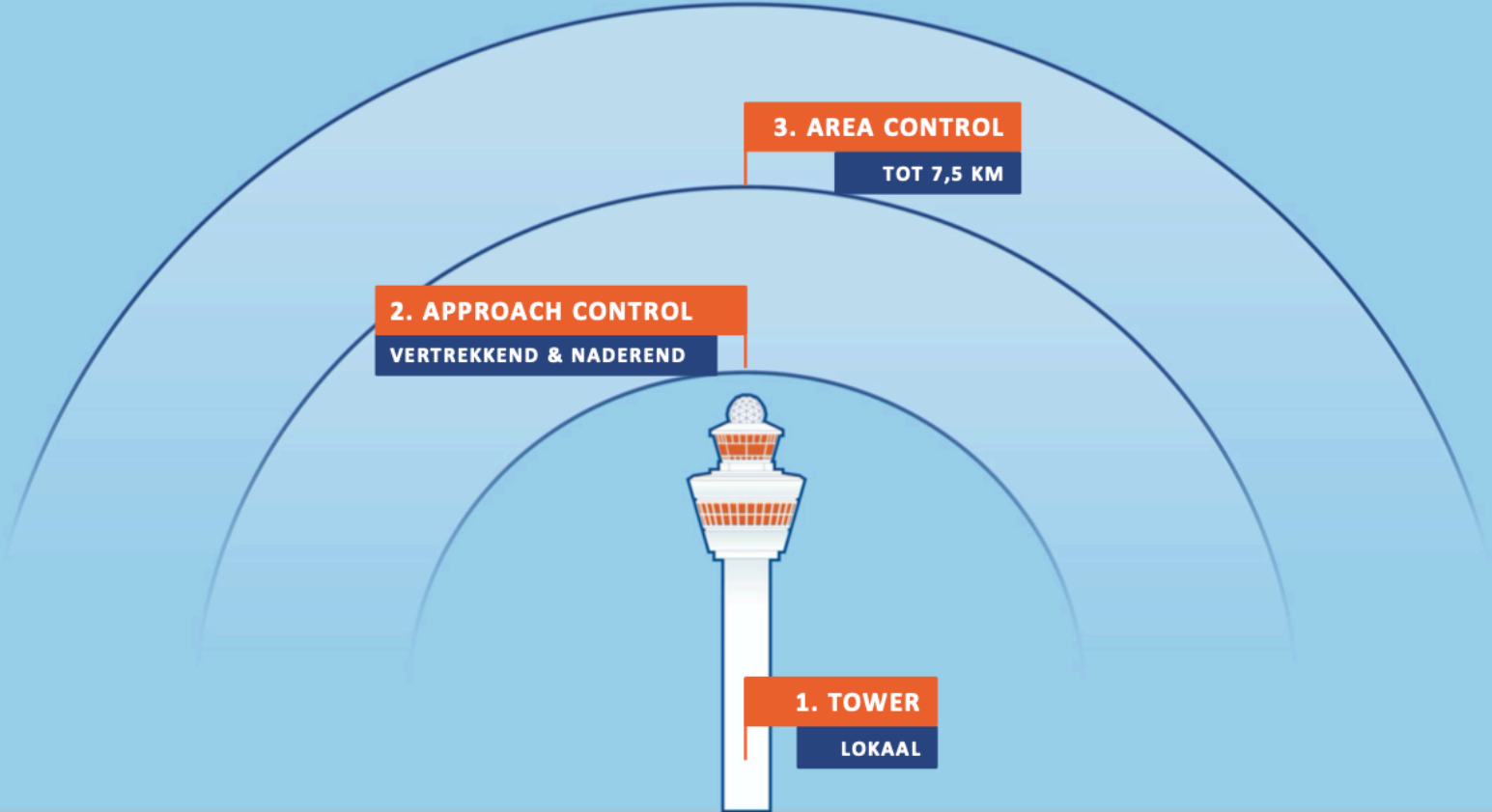

Our Networks facilitating ATC

What is ATC ?

- Separation of Aircraft in “controlled airspace”
- How?
 - Radar
 - Radio comms



System Failure

- No radar image:
 - Location of aircraft not visible.
- Voice comms:
 - No possibility to separate aircraft.

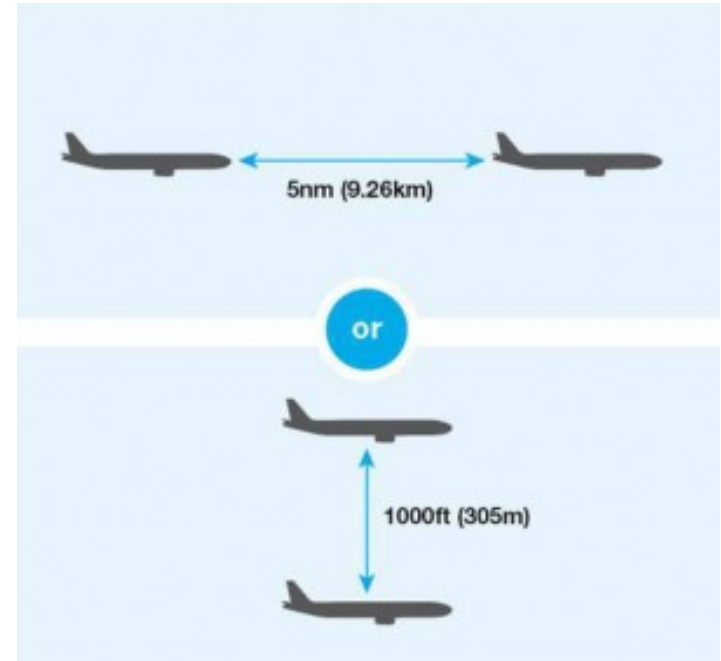
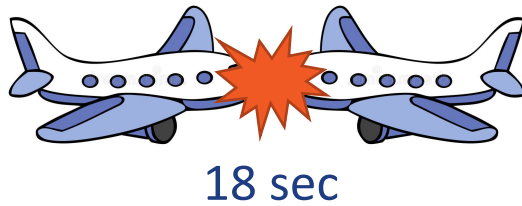

Three lane principle

- Functionality for ATC is “a system”.
- Critical systems: 3-lane principle:
 - Radar screen (eyes).
 - Air-ground voice comms (primary means of communication between controller and pilot).

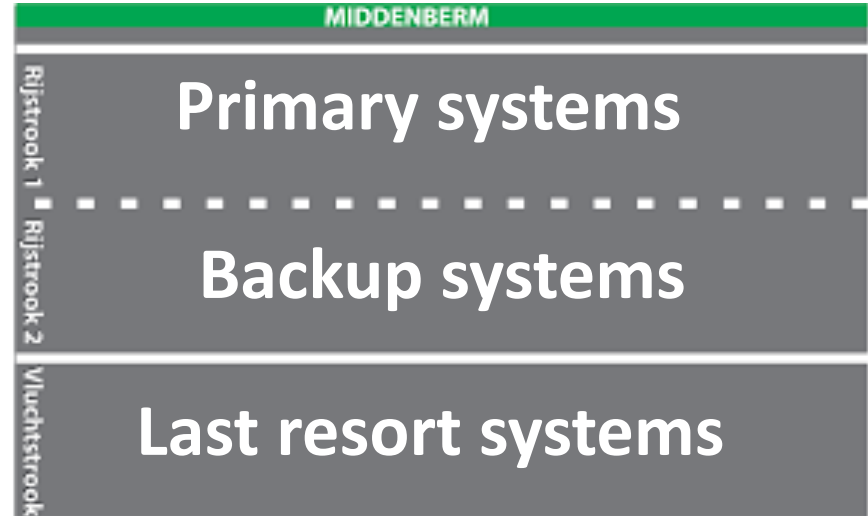

“Systems on multiple networks”

- A number of critical systems are connected to a duplicate LAN network environment:
 - Data is duped on both networks.
 - Switching between networks is up to the application.
 - Almost no interruption in service when switching networks.

Example:

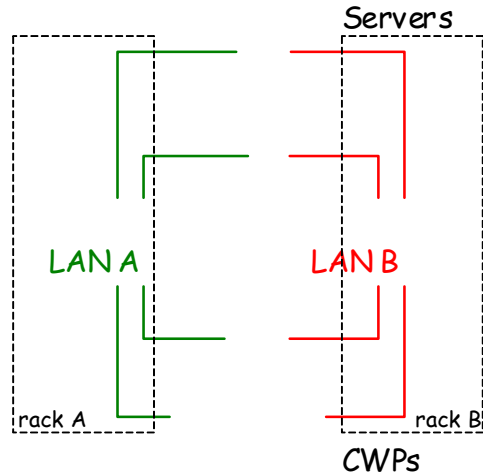

Our Networks

Applications on the LVNL networks (OPS)

- Systems for
 - Pilots
 - ATC.
- Radar screen:
 - Air traffic situation picture (RADAR screen, VDF)
- Voice comms:
 - Ground-Ground voice communication
 - Ground-Air voice communication
- Aux systems:
 - Flightplan data exchange
 - Meteorological data exchange
 - Recording data
 - Monitoring and control
 - Aircraft Navigation data (VOR/DME beacons, ILS at runways)



The Networks

KA network, NON OPS:

- Office
- Support network
- Cisco

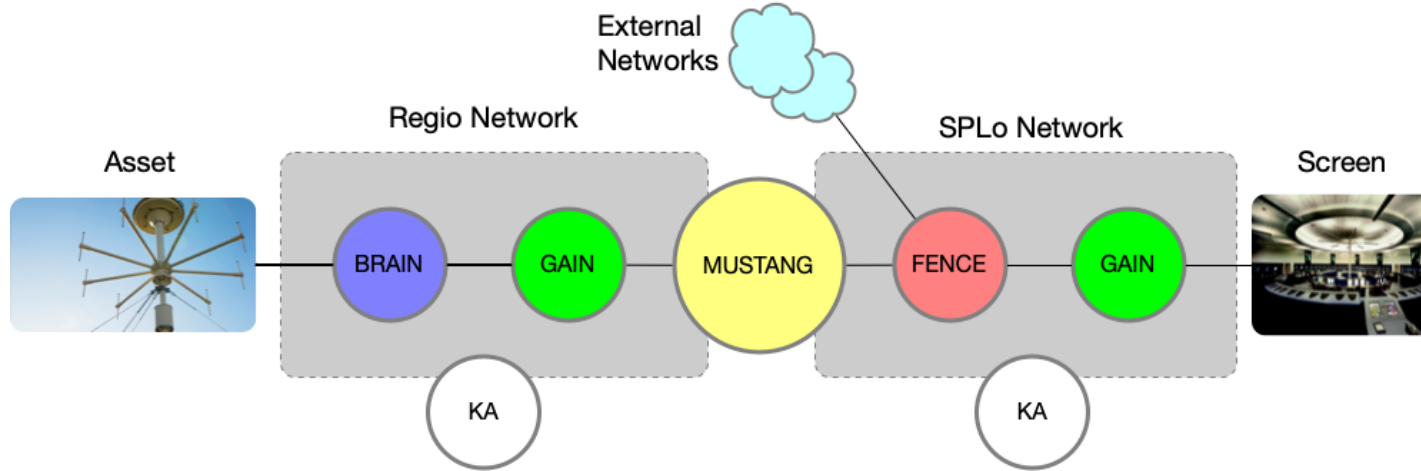

BRAIN Networks:

- Around Airfields
- Sensors (eg. KNMI)
- Ring network
- Cisco

MUSTANG Networks:

- Nation Wide
- Transport
- Cisco

GAIN Networks:

- MAIN ATC LAN
- All systems @ SPLo / reg
- MPLS
- Cisco

FENCE Firewall Infra:

- Networking Security
- Multilayer
- Not disclosed

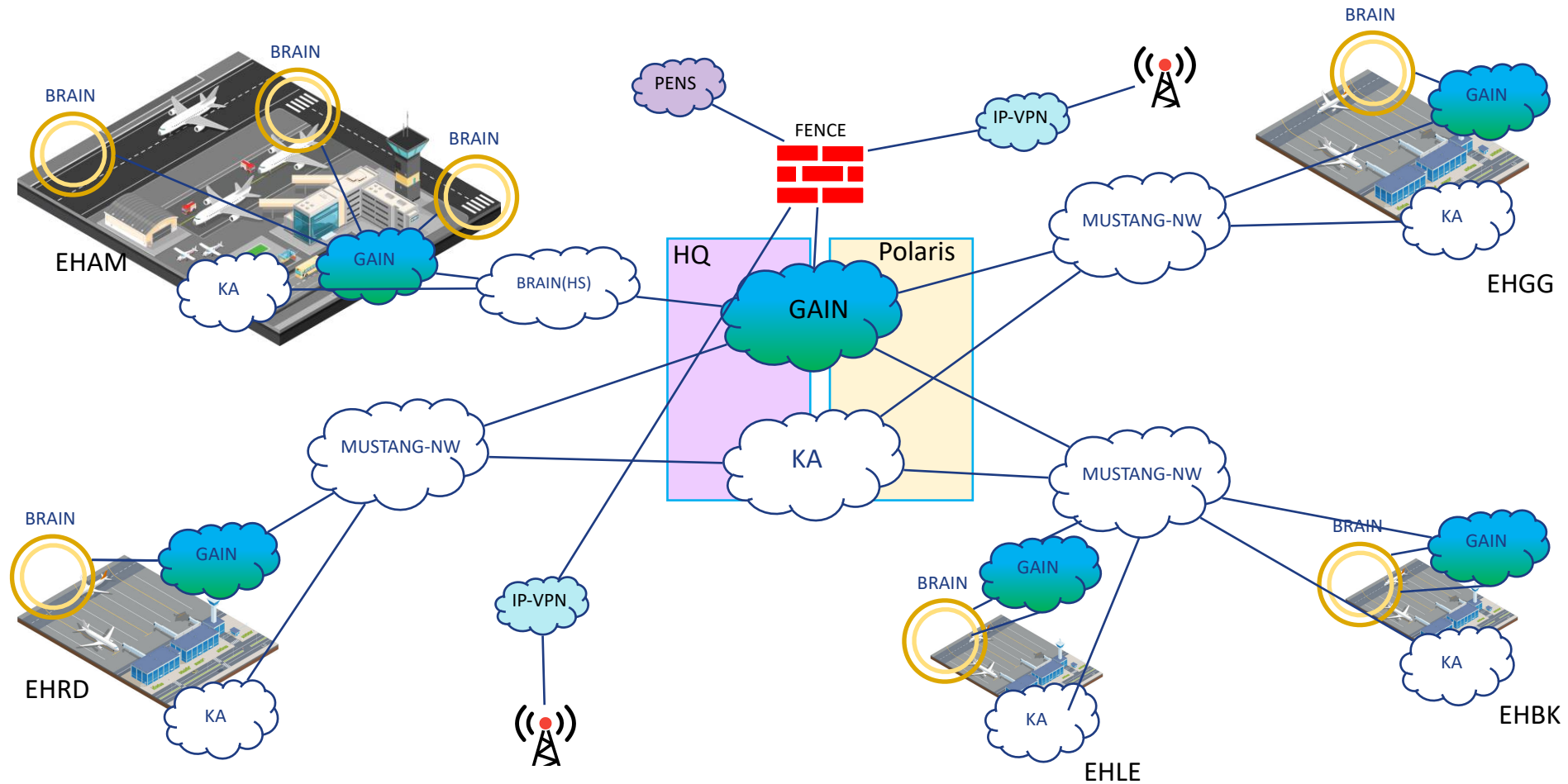

LVNL networks

- History
 - Evolution vs Revolution
 - We do not live in an IP-only environment (yet)
- Life cycle
 - Slow development (on end-systems)
 - Long life (30+yrs)
- Criticalness
 - Uptime
 - Safety
- Complexity
 - Interfaces
 - Redundancy
 - Interconnects
 - Physical
 - Technology
 - Environments
 - DTAE (NON OPS)
 - P (OPS)



How to get this done ?

Continuous Transformations

- Previous situation
 - Product groups (NAV, SUR, AAA, TOWER)
 - Servers
 - Network
 - Infra
- Moving to
 - A LVNL wide
 - Server
 - Network
 - INFRA
- Standardize !
- And here we are....
 - Somebody should do something ...

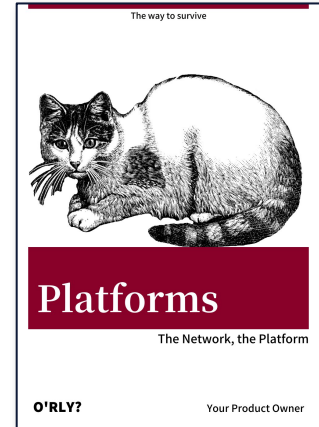
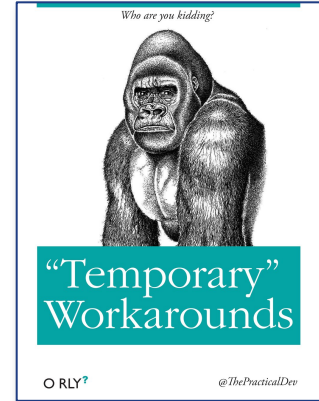
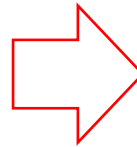
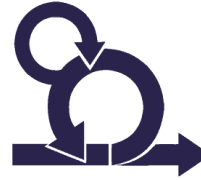
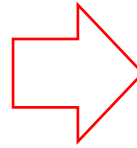

Standardization while

- Integrating 400 + “silo” (legacy) networks
- Supporting loads of projects
 - Building new systems
 - Integrating military fields
- Doing our own LCM
- Act on changing environments
 - 3rd party Infra
 - Regulations and other external factors.
- Optimization of the operation
 - Enhancing Safety
 - New Systems / innovation

But: we are running a 24x7 safety company

- Regulations
 - When, what
- Procedures
 - How, why, backup
- Continuously running operation
 - No time to “close down airspace”
- We need to fix and enhance / replace the plane in mid air!
 - Otherwise, we cannot land anymore
 - Challenges of doing Innovation in a risk averse organization
 - Communication
 - Planning
 - Understanding each others needs and fears
 - Calculated risk vs risk averse

(Back to) the Future

Evolution of the Controller Working Position (data driven, all digital, AI)

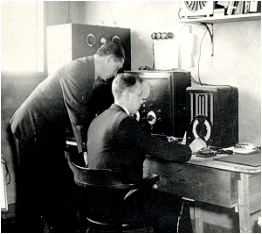

“Luchtverkeersbeveiliging”
(1940)

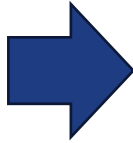

SARP II (1978)

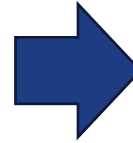

AAA (1992)

2026+: iCAS

Cooperation with DFS

Product of INDRA, Spain

Polaris building @ Schiphol Oost

On the NL-IT top 5 list



Centralised Base / remote tower

- Remote Air traffic control from Schiphol (TWR-W, Eelde, Beek)
- SAAB development
- In use at London City and Norway

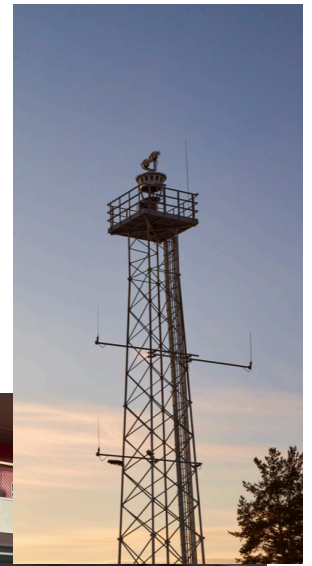

(Tower) Sims

- Educational
- Business critical



1ATM

- Integration of military air traffic control org and systems
- @military airbases LVNL ATC .
- Integration
 - Technical
 - Organization



Questions ??

E-mail: rudi.vandrunen@lvnl.nl



www.lvnl.nl



@luchtverkeersleiding

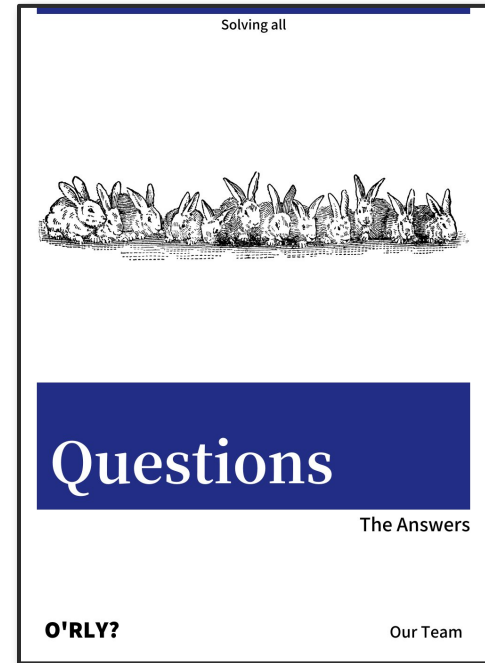

How can you help ?

- Do you like to:
 - Architecture
 - Design
 - Build
 - Maintain
- One of the most complex and critical network environments in NL ?
- There are lots of possibilities for cooperation.